

Thru Beam Photoelectric Sensors



THRU BEAM PHOTOELECTRIC SENSORS BP 1012- BP 1024 FOR AUTOMATIC DOORS RELAY OUTPUT

- Thru beam door sensor with separate amplifier
- 12 o 24 AC/DC input
- Conforming to EN 12978
- 1A relay SPDT
- Sensitivity adjustment
- 6 m long integral cables

BP Series



Identification code

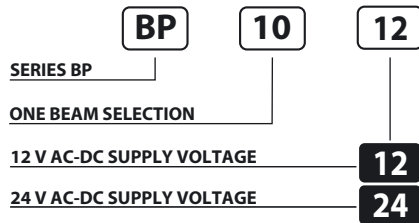

Note: Each package includes a pair of projectors.

AVAILABLE	ONE BEAM SELECTION
NOMINAL SWITCHING DISTANCE (Sn)	10 m
TOLERANCE	+10/-10 %Sn
EMISSION	Infrared (875 nm)
NOMINAL VOLTAGE	12 or 24 VAC DC (-15 / +10%)
FREQUENCY	50 ÷ 60 Hz
OUTPUT	2 Relay
N° OF OPERATIONS	(5x10 ⁶ mec. op. -3x10 ⁵ elect. op.)
MAX OUTPUT CURRENT	1A 24 VDC - 0.5A 120 VAC
ABSORPTION	70 mA
YELLOW LED	Output and activated thru beam indicator
GREEN LED	Supply indicator
SENSITIVITY ADJUSTMENT	Present
SWITCHING FREQUENCY	5 Hz
RESPONSE TIME	200 mS
START UP DELAY	≤ 300 mS
TEMPERATURE LIMITS	-20 ÷ +60°C
LIGHT IMMUNITY	5000 Lux ⁽¹⁾
PROTECTION DEGREE Amplifiers	IP 54
PROTECTION DEGREE Projectors	IP 65
CONNECTIONS	with connectors
HOUSING MATERIAL Amplifiers	ABS
HOUSING MATERIAL Projectors	Body - Lenses: methacrylate
WEIGHT (Approximately)	300 g

⁽¹⁾ Determined with halogen tungsten lamp 3000° K.

Important warning

The thru beam photoelectric sensor can be used as a sensor to detect the presence of an obstacle if the sensing beam gets interrupted.
In no case this device can substituted the obligatory safety devices that must be applied on all dangerous equipments.

Wiring diagrams

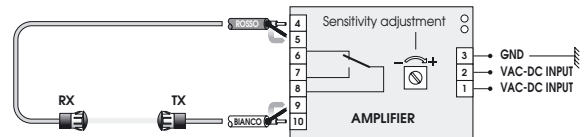

Amplifier dimensions (mm)

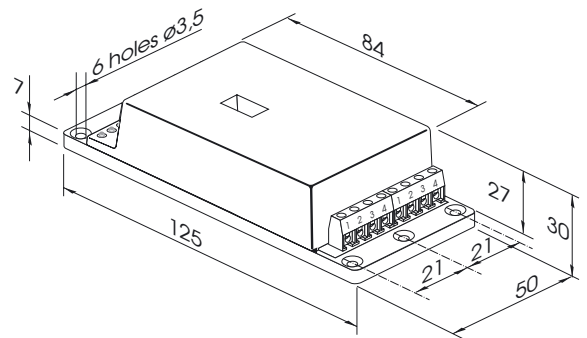

Projector dimensions (mm)

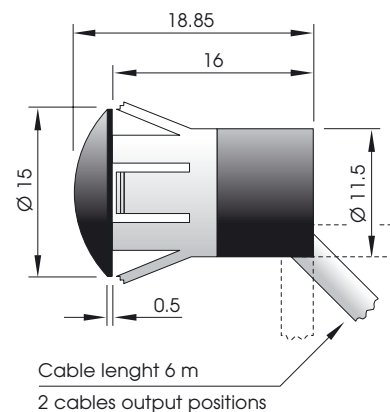

Characteristics curve

